

Automatic Screen Filter Udimatic

Installation- Operation- and Maintenance Manual



Subject to modifications.
No liability accepted for errors or misprints

INDEX

1 - Technical specification.....3

2 - Operating principle.....5

3 - Installation procedures.....6

3.1 - Assembly prior to installation.....6

3.2 - Filter installation.....6

3.3 - Drain line installation.....6

4 - First commissioning and routine start-up.....7

4.1 - Filter initial pre-sets.....7

4.2 - First commissioning.....7

4.3 - Start-up.....7

5 - Filtron flushing controller8

6 - Hydraulic scheme.....13

7 - Shut down & draining procedures.....14

7.1 - Shut down procedure.....14

7.2 - Drainage procedure.....14

8 - Preventive maintenance & inspections.....15

8.1 - Daily15

8.2 - Monthly15

8.3 - Quarterly15

8.4 - Yearly15

8.5 - Two years.....16

8.6 - Three years.....17

8.7 - Instructions for cleaning the screen.....17

9 - Trouble shooting.....18

10 - Spare parts.....19

10.1 - Illustrated Parts Breakdown.....19

10.2 - Part list.....20

11 - Head loss / flow.....22

11.1 - Head loss table *.....22

11.2 - Head loss graph *.....22

11.3 - Application guideline.....23

1 - TECHNICAL SPECIFICATION

Screen Area & Maximum Flow Rates

Model	Inlet/Outlet diameter		Max. Flow Rate	Flush Flow Rate	Screen Area
	inch	mm			
785290	1" (thr.)	25	7	2 - 3	270
7851B91	1½"	40	15	5	850
7851B92	2"	50	25	5	850
7851B93	3"	80	40	5	1450
7851E94	4"	100	80	10	2360
7851964	4"	100	80	10	4500
785196	6"	150	150	10	4500
785198	8"	200	300	14	6200

The maximum flow rate refers to screens over 200 microns/ less than 80 mesh.
For a finer filtration degrees consult our representative.

Screen Grades

Micron	75	100	130	200	300	400
Mesh	200	150	120	80	50	40

* Other screen grades are available.

Electrical Data

Standard 230 V / 110 V – 50 Hz. For use of 110 V internal modifications have to be made.
DC models available on request.

Materials:

- Filter body: Polyester-coated steel (option: stainless steel)
- Rubbers: Natural rubber NR
- Filter element: Super Screen; multiple layers of stainless steel, sintered filter pack (1" and as option: PVC screen)

Construction

The standard housing of the filter is made of carbon steel with a 120 micron protective coating of extra durable polyester, applied electro-statically and oven cured on a zinc-phosphate layer, for maximum anti-corrosion protection both internally and externally.

Access to the internal parts of the filter is through the removable bolted cover.

All immersed parts are made of either plastic materials or non-corrosive metals to ensure many years of trouble free operation.

For special applications; contact our representative for more information.



Type	Unit	785290	7851B91	7851B92	7851B93	7851E94	7851964	785196	785198
Connection B	inch	1"	1½"	2"	3"	4"	4"	6"	8"
Capacity *	m³/h	7	15	25	40	80	80	150	300
Flange (ISO 7005 PN10)									
Pitch C	mm	thread	110	125	160	180	180	240	295
Holes	mm		4 x Ø18	4 x Ø18	8 x Ø18	8 x Ø18	8 x Ø18	8 x Ø22	8 x Ø22
Weight	kg	11	26	28	41	48	62	65	78
Diameter D	inch	6	10	10	10	10	12	12	12
Total height H	mm	500	600	600	770	905	1310	1310	1530
Total width E	mm	410	540	540	540	540	600	600	600
Centre distance A	mm	150	230	230	280	280	540	540	700
Centre distance T	mm	155	220	220	220	220	320	320	320
Filter surface	cm²	270	850	850	1450	2360	4500	4500	6200
Drain valve	inch	1 x 1"	1 x 1½"	1 x 1½"	1 x 1½"	1 x 1½"	1 x 2"	1 x 2"	1 x 2"
Flushing cap. min.	m³/h	2 - 3	5	5	5	10	10	10	14
Flushing press. min.	bar	1 - 2	1 - 2	1 - 2	1 - 2	1 - 2	1 - 2	1 - 2	1 - 2
Flushing water appr.	ltr	6	10	10	15	30	40	40	55

* capacity based on 300 micron screen and good water quality.

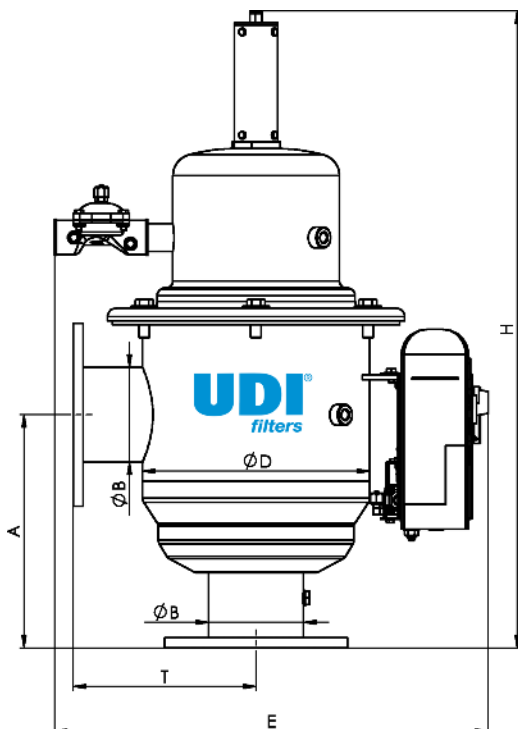

Type	B	A	D	E	H	T
	inch	mm	inch	mm	mm	mm
785290	1"	150	6"	410	500	155
7851B91	1½"	230	10"	540	600	220
7851B92	2"	230	10"	540	600	220
7851B93	3"	280	10"	540	770	220
7851E94	4"	280	10"	540	905	220
7851964	4"	540	12"	600	1310	320
785196	6"	540	12"	600	1310	320
785198	8"	700	12"	600	1530	320

2 - OPERATING PRINCIPLE

A. Normal flow pattern

Raw water enters the filter through the inlet port, passing through the fine screen (1) and out to the outlet port. The sediments stopped on the screen (1) create a "cake" of sediment. This "cake" improves filtration efficiency as it performs a finer filtration. The sediments accumulated on the screen, create a differential pressure across the screen. The differential pressure rises until the predetermined value is reached [normally 0.5 bar].

A differential pressure switch will activate the self cleaning process. A timer backup guarantees that the time passed from the last self cleaning process will not be longer than the preset value determined by the user.

B. Self cleaning

On a flushing command, the flushing valve (6) opens to the atmosphere and creates pressure drop in the motor chamber (5), causing the dirt on the screen to be sucked in by the nozzles (2). This pressure drop also moves the piston (7) and the collector in a linear movement. In addition, the hydraulic motor (4) rotates the collector.

These two processes performed simultaneously create a spiral movement of the nozzles so they cover the whole screen surface, enabling complete and effective cleaning of the screen.

The entire process takes seconds (according to specific model), upon completion of the cleaning process the filter returns to its initial position.

This self cleaning flushing cycle can be initiated by DP switch, timer backup or manually.

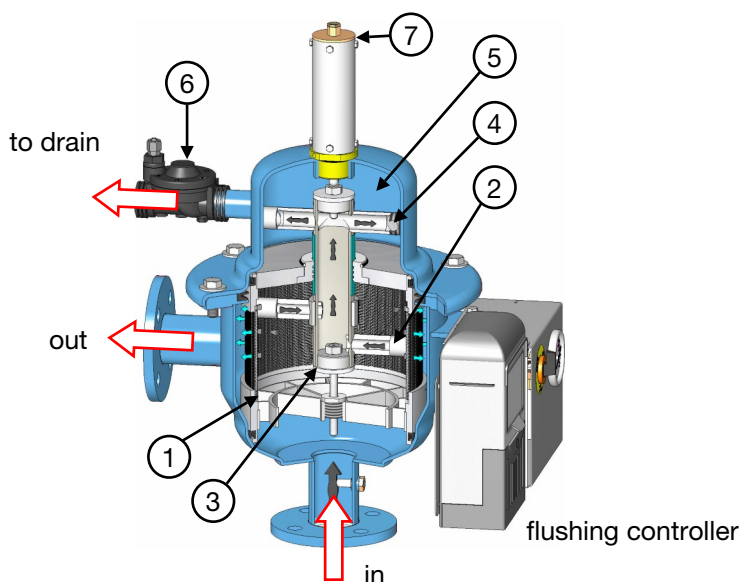

3 - INSTALLATION PROCEDURES

3.1 - Assembly prior to installation

The filter is normally supplied fully assembled.



Electrical connections will be done by authorized personnel only.

Install the filter only in vertical position.

3.2 - Filter installation

1. For best results, the filter should be installed as near as possible to the system it is required to protect. However, if low filter inlet pressure is a concern, either before or during flushing, the filter may need to be installed closer to the pressure source.
2. Ensure that the upstream pipe size from the pressure source to the filter is equal to or greater than the filter's inlet size.
3. A pressure relief valve must be installed before the filtering installation if the pressure is not controlled effectively.
4. It is strongly recommended to install an isolation valve at the filter's inlet, and a check valve, or an isolation valve at the filter's outlet.
5. An inlet isolation valve must be installed in situations where the pressure source cannot be shut down for maintenance.
6. Ensure that the filter is mounted in the proper flow direction, as indicated by the arrows on the filter housing.
7. Ensure that sufficient space is provided around the filter for maintenance.

3.3 - Drain line installation

A drain line should be attached to each flushing valve, as follows:

- The back pressure at the flush valve outlet should not exceed 3 meters (0.3 bar, 4.5 psi)
- Piping should be installed level or pitch down to avoid back-pressure.
- The open end of piping should be securely mounted to avoid fluttering during flushing cycle.



UVAR

Subject to modifications
No liability accepted for errors or misprints

4 - FIRST COMMISSIONING AND ROUTINE START-UP

NOTE: The differential pressure switch and timers have been preset to the proper settings. Do not adjust prior to start-up.

4.1 - Filter initial pre-sets

1. The differential pressure switch is set to 5m (0.5 bar, 7 psi) maximum, do not adjust.
2. The flushing duration is set to:

Type		Time (s)	Type		Time (s)
785290	1"	8	7851E94	4"	14
7851B91	1½"	12	7851964	4"	16
7851B92	2"	12	785196	6"	16
7851B93	3"	12	785198	8"	16

3. Flushing interval (time between one flush to the next one) should be set according to water conditions, the default is set at 2 hours.

4.2 - First commissioning

Check prior to start-up the following. Adjust when required.

1. Check that the line pressure will always be at least 2 bar (20mWC) at the filter inlet during the flushing cycle.
2. Check that there are no upstream pipeline restrictions.
3. Check that the filter is mounted in the correct flow orientation as indicated by the arrows on the body.
4. Check that the flushing valve is mounted properly.
5. Check that the tubing connections are completed.
6. Check that power is available to the Filtron flushing controller.
7. Check that the flushing valve drain lines are installed.
8. Check that the upstream and downstream isolation valves are closed.
9. Check that adequate space is available around the filter for maintenance.

4.3 - Start-up

1. Slowly open the inlet valve to the filter allowing the filter to pressurize.
2. Check for any external leakage and eliminate.
3. Disconnect the control tube from the hydraulic piston and bleed it until all of the air is displaced by water. Reconnect the control tube.
4. Slowly open the outlet valve of the filter (if installed).
5. Initiate a manual flushing; observe the inlet and motor chamber pressures (use three way valve and manometer mounted on the control box). The motor chamber pressure should be between 0.8-1.5 bar below inlet pressure during the flushing cycle. Minimum inlet pressure during flushing cycle should be 2 bar (30 psi) for all models.
6. Observe the differential pressure's build up across the filter. It is recommended to observe at least one full cycle to ensure that the system is operating properly.

NOTE: At any given time pressing the manual flushing push button will cause one flush cycle. The flushing cycle duration can be adjusted via the controller, it is recommended not to shorten or prolong the flushing time for it will not clean the whole screen area or use an excessive amount of water.

5 - FILTRON FLUSHING CONTROLLER

General instructions:

The flush controller is made and designed to flush semi-automatic filters. After installation of the Filtron, it can flush the filter at a preset time, pressure difference or on manual activation. The flushing controller can, as an option, be modified for use with a pressure-maintenance/main valve and an alarm output.

Installation instructions:

Mount the flush controller in an easily accessible place. If the flush controller is exposed to more than occasional water splashes, it needs to be protected against this with a cover or casing.

Programming the controller:

The controller is equipped with an LCD display and 4 keys as displayed below. When the unit is left untouched for a minute the display is switched off and the only life signal is given by a beep sound that can be heard every 20 seconds. Holding down any of the keys for a few seconds will bring the screen back to life.

The screen consists of several fields, some of them are editable and some of them are not. For inserting EDIT MODE the ENTER key has to be pushed. The EDIT MODE is indicated by blinking of the characters at the currently editable field. Each time the ENTER key is pushed again, the next editable field becomes under focus and starts blinking. While in EDIT MODE the "+" and "-" keys can be used for changing the value under focus. Pushing the ENTER key again will set the selected value to the current field and move the focus to the next editable field which will start blinking. Once entering this process of passing through the editable fields, the user has no way back but by pushing the ENTER key repeatedly, he passes through the chain of editable fields until arriving back to the FLUSH TIME field, meeting no more blinking fields.

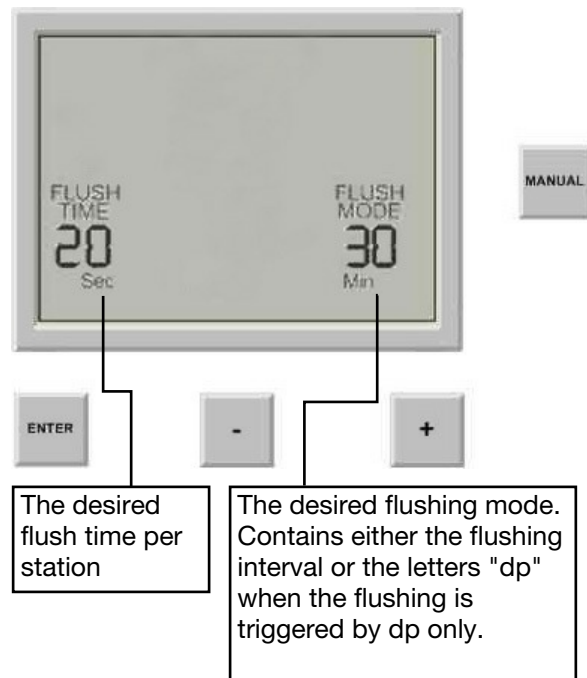

Notice: that before the first use of the unit, it may be necessary to pass through the configuration process prior to defining the flushing program in order to adjust the features of controller to the specific application. The configuration process is described below.

The series of editable fields:

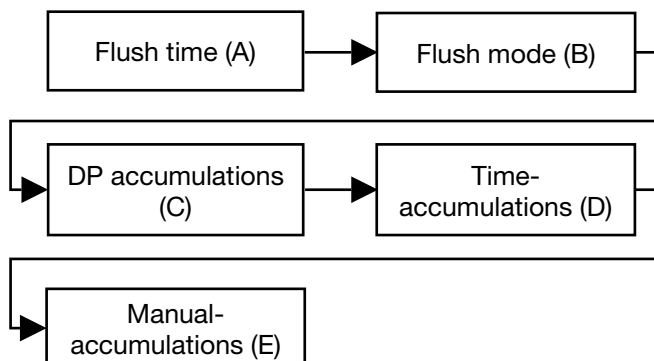

(A) The flush time:

Defines the duration of the flushing time per station. The following options are selectable:

- 5-20 sec in steps of 1 sec
- 20-55 sec in steps of 5 sec
- 1-6 min in steps of 0.5 min

The DP setting:

As standard, the Filtron is supplied with an external electronic pressure difference switch. The DP setting is determined on the external DP sensor, which is set as standard to 0.5 bar. The flush request signal is indicated in the form of a closed dry contact on the relevant input terminals.

The pressure difference of the external DP sensor may be set using the screw on the side. One whole turn of 360° adjusts the pressure difference by 0.1 bar.

Turn anticlockwise to reduce the switching pressure.
Turn clockwise to increase the switching pressure.



(B) The Flush Mode:

The Flush Mode determines how the flush cycle is activated. The selectable options are:

- **OFF** - no flushing will take place
- **By time** – In this case the flushing cycles will be repeated in a selected interval or will be triggered by the DP signal depending on what happens first. No matter how was the flushing cycle started the interval to the next cycle will start to be measured again after each ending of a flushing sequence. The selectable intervals are the following: 5, 10, 15, 20, 25, 30, 35, 40, 45, 50, 55, 60 minutes 2, 3, 4, 5, 6, 8, 12, 18, 24, 72, 120 hours
- **dp** – flushing will be triggered by DP only.

Note: When the keys '+' and '-' are pressed at the same time, in the field 'Flush Mode' the remaining time until the next cycle is shown in alternating hours and minutes.

(C D E) Accumulations:

The unit independently accumulates and displays the number of flush cycles that are initiated by DP, on time or manually.

For each of the accumulation fields, the '+' or '-' keys can be used to clear the accumulated value.

The configuration process:

Start the configuration process by holding the ENTER key pressed in for at least 3 seconds. The unit detects how many plug-in boards (each with two outputs) are in use in the specific case.

How the outputs are assigned depends on the definitions that are set during the configuration process described below. The following rules apply:

1. Backflush valves will be allocated starting from output 1 and up.
2. The last backflush valve can be canceled and then its allocated output will be left unused.
3. Alarm output, Delay-Valve and Main-Valve when defined, will be allocated in this order, right after the last backflush valve (whether in use or not).

Example:

In the case of three plug-in boards, six outputs can be used. In the absence of an alarm output, a delay valve and a main valve, all the six outputs are assigned to back-flow valves.

If a main valve is defined, the first five outputs are assigned to back-flow valves and output no. 6 is assigned to the main valve. Output no. 5 (for the last back-flow valve) can be disabled and then remains unused. If a delay valve is also defined, this is assigned to output 5, immediately prior to the main valve. The first four outputs are then available for back-flow valves and of these output 4 (for the last back-flow valve) can be disabled. This output then remains unused. If an alarm output is also defined, this is assigned immediately prior to the delay valve. In this case only the first three outputs are available for back-flow valves. Output 3 can be disabled (disabling is possible in View Outputs using the manual key).

During the configuration process, the following functions are defined:

Main valve (pressure maintenance valve): Yes/No. If the answer is 'Yes', the Pre-Dwell delay between the main valve opening and the opening of station no. 1 can be defined. The selectable delay steps are: 5 - 10 - 15 - 20 - 25 - 30 - 35 - 40 - 45 - 50 - 55 seconds - 1 - 1.5 - 2 - 2.5 - 3 - 3.5 - 4 - 4.5 - 5 - 5.5 - 6 minutes

Dwell time: The delay between stations can be set to 5 - 10 - 15 - 20 - 25 - 30 - 35 - 40 - 45 - 50 - 55 or 60 seconds.

DP delay: The delay during which the DP sensor reading is expected to remain stable for a reaction can be set to 5 - 10 - 15 - 20 - 25 - 30 - 35 - 40 - 45 - 50 - 55 - 60 seconds.

Looping limit: The number of successive flush cycles activated by the DP sensor that can be conducted before it is established that an endless loop problem has arisen. The options are: 1-10 or 'no', which means that the loop problem is ignored.

Alarm: Yes/No. An output is assigned for alarm activation.

Delay Valve: Yes/No – an output is assigned to activation of the delay valve.

View Outputs: This is a special mode with which the list of outputs can be gone through to see how each output is assigned. Use the '+' key to change 'no' to 'yes' and confirm with ENTER. Then use the '+' key to step through the list. The ordinal number of the output is displayed in the bottom left corner. The function that is assigned to the output is displayed in capital letters in the middle of the screen. The possible number of outputs that can be used is always an even number, because it is calculated based on the number of plug-in boards used (each with two outputs). If the number of outputs needed is an odd number, however, the last valve that is assigned to flushing can be disabled using the manual key for manual operations.

Pressure units: The units that are used for pressure measurements. Choice of bar or psi. This is not applicable for an external pressure difference switch.

Calibration: Zero calibration of the built-in electronic DP sensor. Select 'Calibration = Yes' with the sensor ports disconnected (disconnect high and low pressure hoses for calibration). This is not applicable for an external pressure difference switch.

Version display: The last screen of the configuration contains information about the controller's software version. The versions consist of four figures, such as:

00
13

Reset: When adding or removing a plug-in board, always switch off the power. This also resets the controller.

Solving endless loops:

As explained above, endless looping problem will be declared when the number of consecutive flushing cycles triggered by the DP sensor exceeds the "Looping limit" defined during configuration. The fact that endless looping problem was detected will be indicated on the display and will cause the activation of the Alarm output, additionally, the DP indication will no longer be considered as a trigger for flushing. The following flushing cycles will be triggered by the interval count down only.

Low pressure:

When a closed contact indication is received at the low pressure input of the controller, the symbol  will start to appear blinking at the display. All activities will stop including the countdown to the next flushing cycle. If the low pressure happened while a flushing sequence was in progress, when the low pressure condition terminates the flushing sequence will start from the beginning rather than continue from the stop point.

Manual activation:

A flushing sequence can be manually activated by the "MANUAL" key. When manually activated the icon  will appear on the display. The same key will be used for manually terminating a sequence in progress.

Adding and removing of plug-in units:

The number of connections on the Filtron may be altered with plug-in units. Before the configuration is altered, the power must be removed from the unit.

The addition and removal of the plug-in units happens by sliding the bottom dark grey cover downwards. Ensure that the plug-in units are all in the left-hand connectors, so when adding units, work from left to right.

Slide the plug-in unit carefully part way into the connector until the plastic bracket at the bottom fits into the hole and then slide the unit fully home.

Removal happens in the reverse order.

Technical data:

AC model:

Power supply: 220 or 110 V AC 50 or 60 Hz with built-in transformer to 24 V AC.

Outputs: 24 V AC solenoids.

DP sensor:

Standard: external dry contact DP sensor.

Option: built-in electronic analogue DP sensor.

Pressure sensor: dry contact pressure sensor (option)

Ambient temperature: 0-60°C.

Wiring diagram, AC model:

The illustration below shows the wiring for the AC model of the controller.

Note:

1. The external DP sensor is standard and is intended for use when the unit does not feature a built-in electronic DP sensor (option).
2. The unit is supplied with 24 V AC, internally transformed from 220/110 V AC.
3. Switch off the power before removing/adding a plug-in unit.

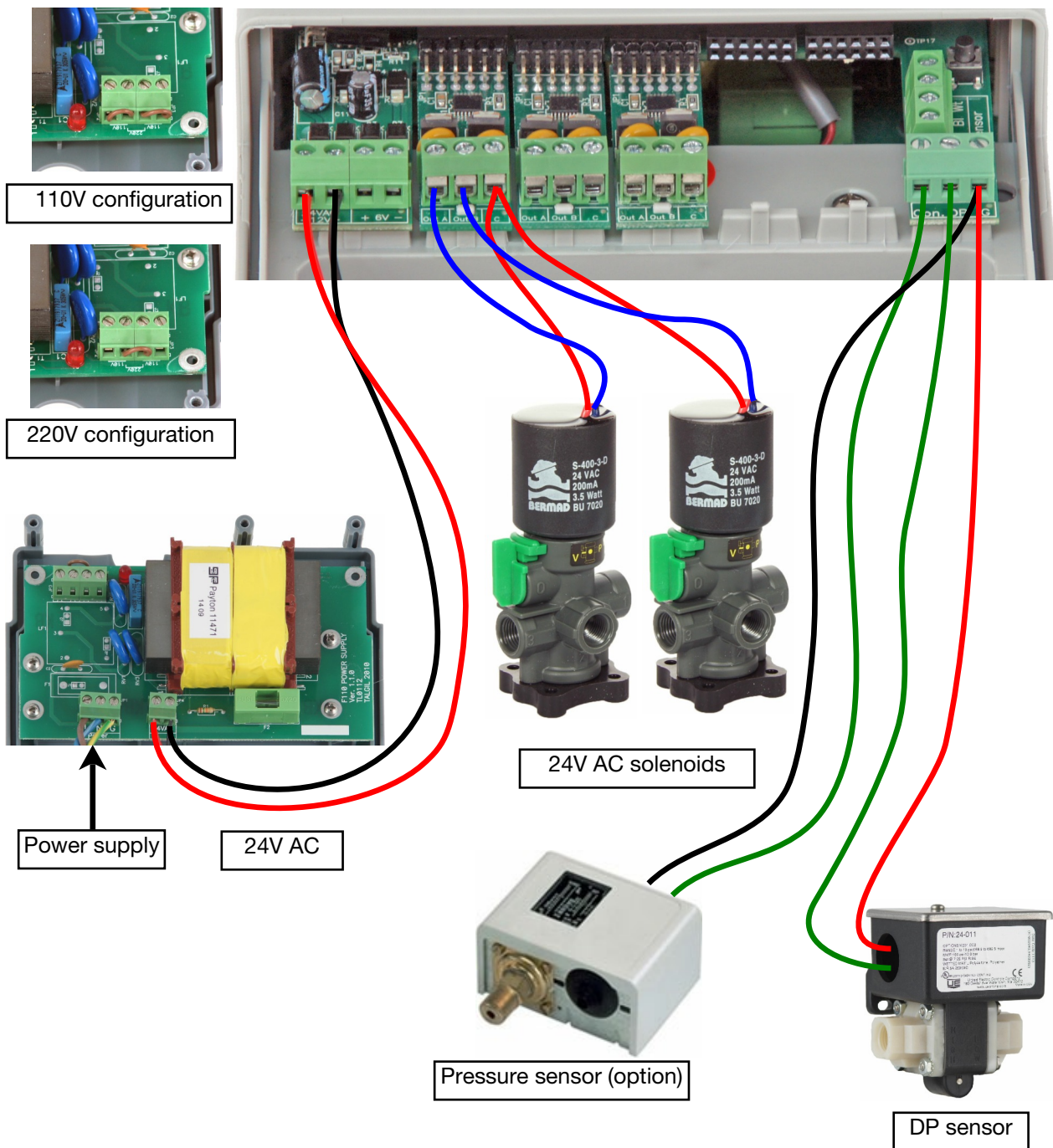

6 - HYDRAULIC SCHEME

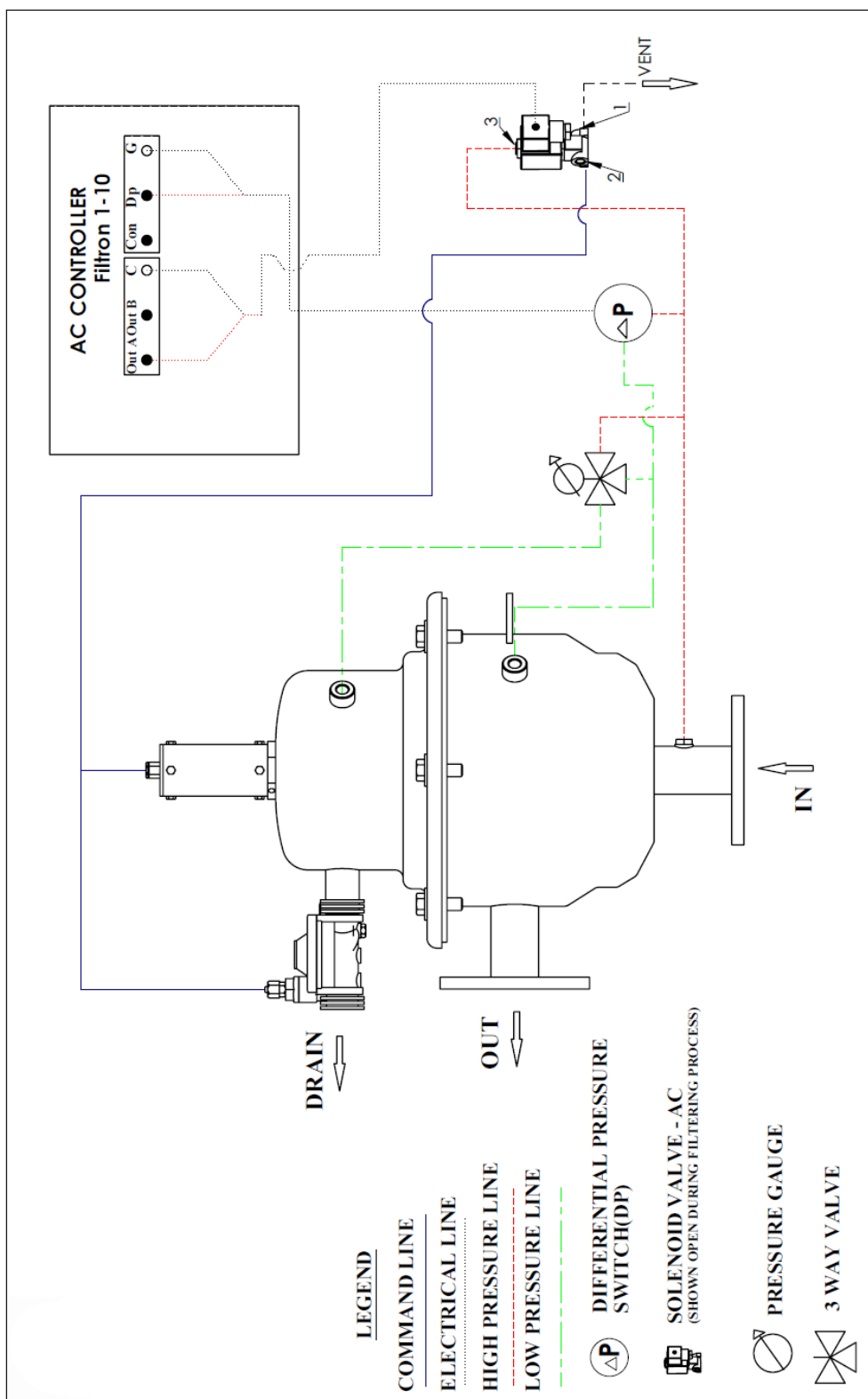

7 - SHUT DOWN & DRAINING PROCEDURES

7.1 - Shut down procedure

NOTE: Before filter shut down or draining, perform two cycles of manual flush, verify that head loss on the filter does not exceed 0.1-0.2 bar (1-2 meters).

1. Close the isolating valve on the outlet of the filter if equipped.
2. Initiate a manual flushing by pressing "M" on the flushing controller.
3. Close the isolating valve on the inlet of the filter
4. Initiate an additional manual flushing cycle to relieve the pressure in the filter.

7.2 - Drainage procedure

Prior to accessing filter internals, it is necessary to drain the filter. Note that uncontrolled emptying of the filter may result in excessive water spillage in the area around the filter.

8 - PREVENTIVE MAINTENANCE & INSPECTIONS

General notes:

1. In case that there is a need to drain the filter completely, perform manual flush before draining the filter.
2. (□) refers to the breakdown drawings of chapter 9.
3. Before installing seals and O-rings back to their places, apply silicone grease 'DOW CORNING 4DC' or equivalent grease (unless otherwise noted).

 4. Do not tighten / untighten bolts while the filter is pressurized.

Following is a schedule of preventive maintenance and inspections based on average filtration duty, and should be used as a guideline only. For best results, a maintenance schedule should be compiled based on experience gained from using the filter. Maintenance kit (paint and grease) is attached to the filter.

8.1 - Daily

Repair any damage to the protective coating of the filter without delay. Prior to application of protective paint, thoroughly clean the damaged spot with wire brush.

8.2 - Monthly

On units equipped with by-pass valve, the by-pass should be engaged at least once a month. This will clean the valve seat of any accumulated dirt, as well as ensuring proper by-pass operation.

8.3 - Quarterly

Depressurize the filter; disconnect the command pipes from the piston. Dismantle the piston from the filter by unscrewing the piston out. Pull out piston rod (4) lubricate the piston rod with Dow Corning 4DC or equivalent grease. Push the piston rod back inside and install the piston back. Bleed the air from the command pipes until all the air is displaced by water, connect the command pipes back. Perform start-up procedure for filter (see par. 4.3).



8.4 - Yearly

Every year lubricate the piston internal parts with lubrication grease. Depressurize the filter and disconnect the command pipes from the piston. Dismantle the piston from the filter by unscrewing the piston out.

1. Screw out the bolts (1), and pull the front flange (2) out.
NOTE: do not unscrew the rear bolts (3)

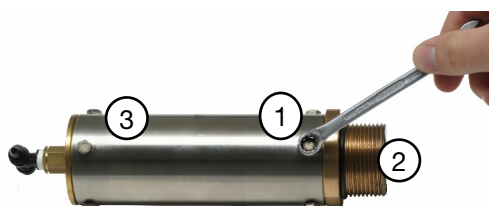



2. Pull the piston bar with the whole assembly (4) out of the cylinder.

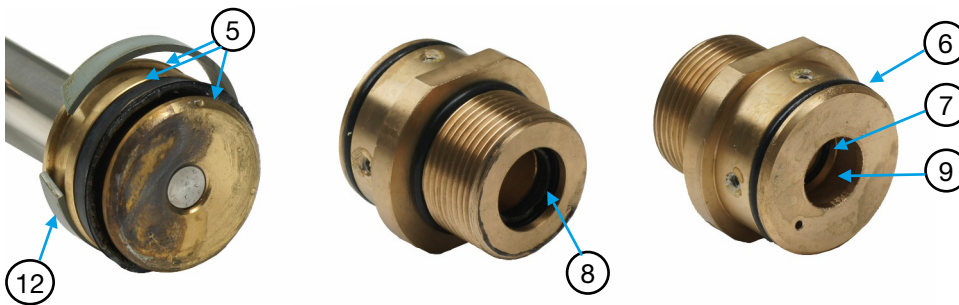

3. Apply a thin layer of Dow Corning 4DC or equivalent grease to following parts: (5), (6), (7) and (8).
4. Fill the inner slot (9) with Dow Corning 4DC or equivalent grease up to the slot edges.
5. Slide the piston (4) assembly into the cylinder; verify that leading strip (12) is placed in its slot. Slide the front flange (2) on the cylinder.

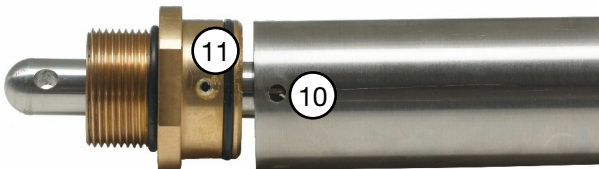

6. Align the screw holes on the cylinder (10) with the screw threads on the front flange (11).
7. Screw the bolts (1), and gently tighten them.
8. Install the piston on the filter, and connect the command pipes back to the "TEE" fitting.
9. Check for water leakage during next operation and flushing process.

8.5 - Two years

Use our maintenance set for bi-annual maintenance and replace all seals.

Model 1"			Model 1½" / 2" / 3" / 4"			Model 4L" / 6" / 8"		
Partcode set 4S78529099			Partcode set 4S7851B9199			Partcode set 4S78519699		
4S801505	Cover seal	1	4S78519103	Cover seal	1	4S71500833	Cover seal	1
4S801504	Screen seal	1	4S7851B9160	Screen seal	2			
			4S7851B9163	O-ring rotor lagerring	1	4S71500804	Screen seal	2
4S78529070	Sealset cylinder	1	4S7851B9170	Sealset cylinder	1	4S78519370	Sealset cylinder	1
4S741000032	Rotorbearing	1	4S741000032	Rotorbearing	1	4S71501003	Rotorbearing	1
4S78529185	Rotor ring	1	4S7851B9185	Rotor ring	1	4S78519685	Rotor ring	1

Instruction for filters (1½" – 8") dismantling and installing:

- Disconnect command pipes from the piston (7).
- Unscrew cover bolts (9) and remove the cover (8).
- Take out the collector assembly (4) by holding the hydraulic motor (4/2) and a slightly pulling upwards.
- Pull out the screen (3 or 3A).
- For replacing upper bearing (11);
 - Separate the collector assembly (4) from the bearing base (10).
 - Unscrew the hydraulic motor locking bolt (4/3) and pull out the hydraulic motor (4/2) from the collector assembly (4)
 - Separate the bearing base (10) from the collector assembly.
 - Remove bearing stopper (5) and pull out the upper bearing (11).
 - Install the new upper bearing into its place in the bearing base (10) and secure it with the bearing stopper (5). Before installing the bearing stopper lubricate it with silicone grease "OKS 1110/0" or equivalent grease.
 - Install the bearing base (10) on the collector assembly (4), install back the hydraulic motor (4/2) and secure it with the locking bolt (4/3).
- For replacing lower bearing (3/3);
 - Take out the screen assembly (3 or 3A).
 - The lower bearing is installed inside the fine screen handle (3/4). Press on the lower bearing from outside (3/3) to pull it out.
 - Insert the new bearing (3/3) into the fine screen handle (3/4) from the inside and press it until it fits in place.
- Verify that the screen seals (3/2) are intact (or replace if necessary), lubricate the seals with silicone grease "OKS 1110/0" or equivalent grease.
- Insert the screen (3 or 3A) assembled with the collector assembly (4) into the filter body and press slightly the bearing base (10) to fit in place.
- Verify that the cover seal (2) is intact (or replace if necessary), lubricate the seal with silicone grease "OKS 1110/0" or equivalent grease and place it in its groove in the filter body.
- Place cover (8), screw in cover bolts (9) and tighten the bolts.
- Connect command pipes back to the piston (7).
- Perform start up procedure and manual flush to the filter.

8.6 - Three years

Replace damaged seals and gaskets of the piston as necessary or every 3 years

Model 1"	Model 1½" 2" 3" 4"	Model 4L" 6" 8"
Partcode set 4S78529070	Partcode set 4S7851B9170	Partcode set 4S78519370

8.7 - Instructions for cleaning the screen

It is recommended to take out the filter screen for cleaning and checking every one year or when head-loss does not decrease after three repetitive flushing cycles due to differential pressure switch.

 **Gently clean the screen using a bristle brush, never use a steel brush.**

NOTE: If a bristle brush does not remove particles from screen, immerse screens in an acid or alkaline solution for some time, then rinse it thoroughly. Recommended solution: 1% - 2% Hydrochloric Acid (HCl), or 5% Sodium Hydroxide (NaOH).

 **Chemicals manufacturer's safety instructions should be read before the using chemicals.**

9 - TROUBLE SHOOTING

Symptom	Cause	Remedy
Filter flushes often	Extra soiled water	Take measures upstream
Pressure loss increases rapidly	Insufficient cleaning: 1. Inlet pressure is too low 2. Outlet pressure is too low	1. Pump at higher pressure 2. Install a pressure-sustaining valve
Discharge-pipe only runs 2-3 sec. (instead of 8-10 sec.)	Rotor does not go up/down	Check cylinder
Filter doesn't flush at pressed button	Electrically and/or valve	Test: disconnect hose
Filter does not flush on ΔP en/or time	Print settings / ΔP -switch	Check power / settings
Flushing ends slowly	In-line filter clogged	Clean

10 - SPARE PARTS

The following page depicts a typical filter assembly and indicates proper part description and location. Please refer to these descriptions (paragraph 9.2) when ordering spare parts.

10.1 - Illustrated Parts Breakdown

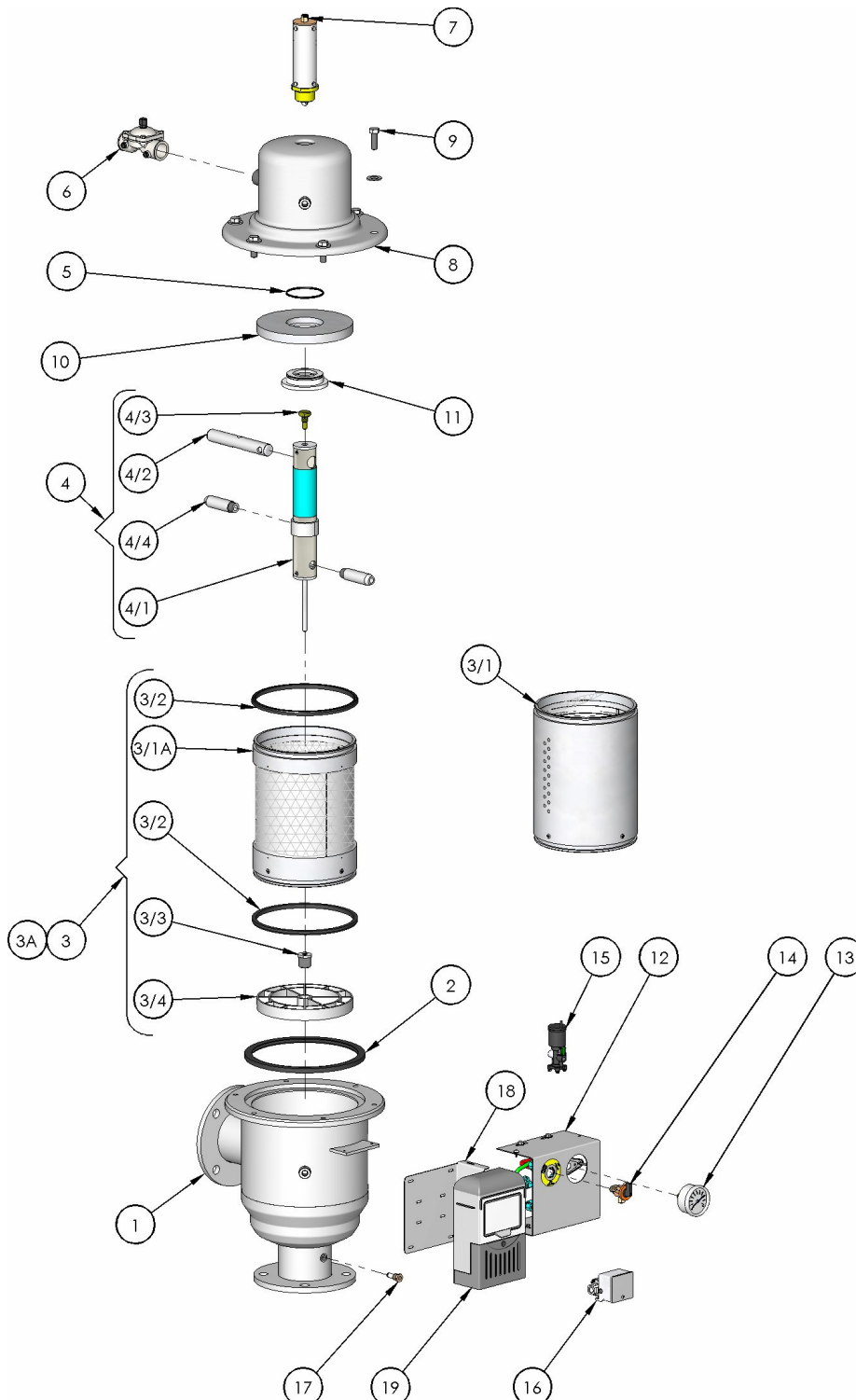

Subject to modifications.
No liability accepted for errors or misprints.

10.2 - Part list

#	Description	1½" and 2"	3 "	4"
2	Cover gasket	4S78519103	4S78519103	4S78519103
3	Fine screen Ass. – (P.V.C)	4S7851B9116...	E8510454	E8510461
3-A	Fine screen Sintered – Ass.	4S7851B9106...	4S7851B9306...	4S7851E9406...
3/1	Fine screen – PVC body	E8510256	E8510456	E8510466
3/1-A	Fine screen Sintered	E8510255	E8510455	E8510465
3/2	Screen Seal	4S7851B9160	4S7851B9160	4S7851B9160
3/3	Lower Bearing	4S741000032	4S741000032	4S741000032
3/4	Fine screen handle	4S78519161	4S78519161	4S78519161
4	Dirt collector – Assembly	4S7851B9108	4S7851B9308	4S7851B9408
4/1	Dirt collector body	4S7851B9187	4S7851B9387	E8515417
4/2	Hydraulic motor	E8510258	E8510258	E8510458
4/3	Hydraulic motor locking bolt	E8510407-BR	E8510407-BR	E8510407-BR
4/4	Suction nozzle	4S78519186	4S78519186	4S78519186
5	Bearing Stopper – "O" Ring	4S7851B9163	4S7851B9163	4S7851B9163
6	Flushing valve	2U20916G	2U20916G	2U20916G
7	Hydraulic piston	4S7851B9107	4S78519370	4S78519370
8	Cover	E8510260	4S7851B9303	4S7851B9303
9	Bolt	4S78519109	4S78519109	4S78519109
10	Bearing base	4S78519184	4S78519184	4S78519184
11	Upper Bearing	4S78519185	4S78519185	4S78519185
12	Pressure control box	Y8510201-MG	Y8510201-MG	Y8510201-MG
13	Pressure gauge	4S78519191	N6111025	N6111025
14	3 way valve selector	PM202500	PM202500	PM202500
15	Solenoid valve AC	2U205400	2U205400	2U205400
15	Solenoid DC latch	2U208402	2U208402	2U208402
16	Pressure switch - NC	1U05010207	1U05010207	1U05010207
17	Mini Control Filter	2S2000046	2S2000046	2S2000046
18	Pressure control box side cover	Y8510204-MG	Y8510204-MG	Y8510204-MG
19	AC Controller	4S785191142	4S785191142	4S785191142
19	DC Controller	N5312222	N5312222	N5312222

#	Description	4"L and 6"	8"
2	Cover gasket	4S71500833	4S71500833
3	Fine screen Ass. – (P.V.C)	E8510604	E8510804
3-A	Fine screen Sintered – Ass.	4S78519606...	4S78519806...
3/1	Fine screen – PVC body	E8510606	E8510806
3/1-A	Fine screen Sintered	E8510616	E8510816
3/2	Screen Seal	4S71500804	4S71500804
3/3	Lower Bearing	4S71501003	4S71501003
3/4	Fine screen handle	ER10016-PL	ER10016-PL
4	Dirt collector – Assembly	4S78519608	4S78519808
4/1	Dirt collector body	E8510607	E8510807
4/2	Hydraulic motor	E8510614	E8510614
4/3	Hydraulic motor locking bolt	E8510407-BR	E8510407-BR
4/4	Suction nozzle	4S78519686	4S78519686
5	Bearing Stopper – "O" Ring	4S7851B9163	4S7851B9163
6	Flushing valve	2U20922G	2U20922G
7	Hydraulic piston	4S78519370	4S78519370
8	Cover	E8510630	E8510630
9	Bolt	4S78519109	4S78519109
10	Bearing base	4S78519684	4S78519684
11	Upper Bearing	4S78519685	4S78519685
12	Pressure control box	Y8510201-MG	Y8510201-MG
13	Pressure gauge	N6111025	N6111025
14	3 way valve selector	PM202500	PM202500
15	Solenoid valve AC	2U205400	2U205400
	Solenoid DC latch	2U208402	2U208402
16	Pressure switch - NC	1U05010207	1U05010207
17	Mini Control Filter	2S2000046	2S2000046
18	Pressure control box side cover	Y8510204-MG	Y8510204-MG
19	AC Controller	4S785191142	4S785191142
	DC Controller	N5312222	N5312222



11 - HEAD LOSS / FLOW

11.1 - Head loss table *

Head loss in bar for flow in m³/h

Model	5	10	15	25	50	75	100	150	200	250	300	350	400	500
785290	0,08	0,31												
7851B91		0,11	0,25											
7851B92			0,07	0,21										
7851B93					0,16	0,36								
7851E94					0,05	0,11	0,19	0,43						
7851964					0,04	0,10	0,17	0,39						
785196							0,06	0,13	0,23	0,35				
785198								0,04	0,08	0,12	0,17	0,23	0,30	

11.2 - Head loss graph *

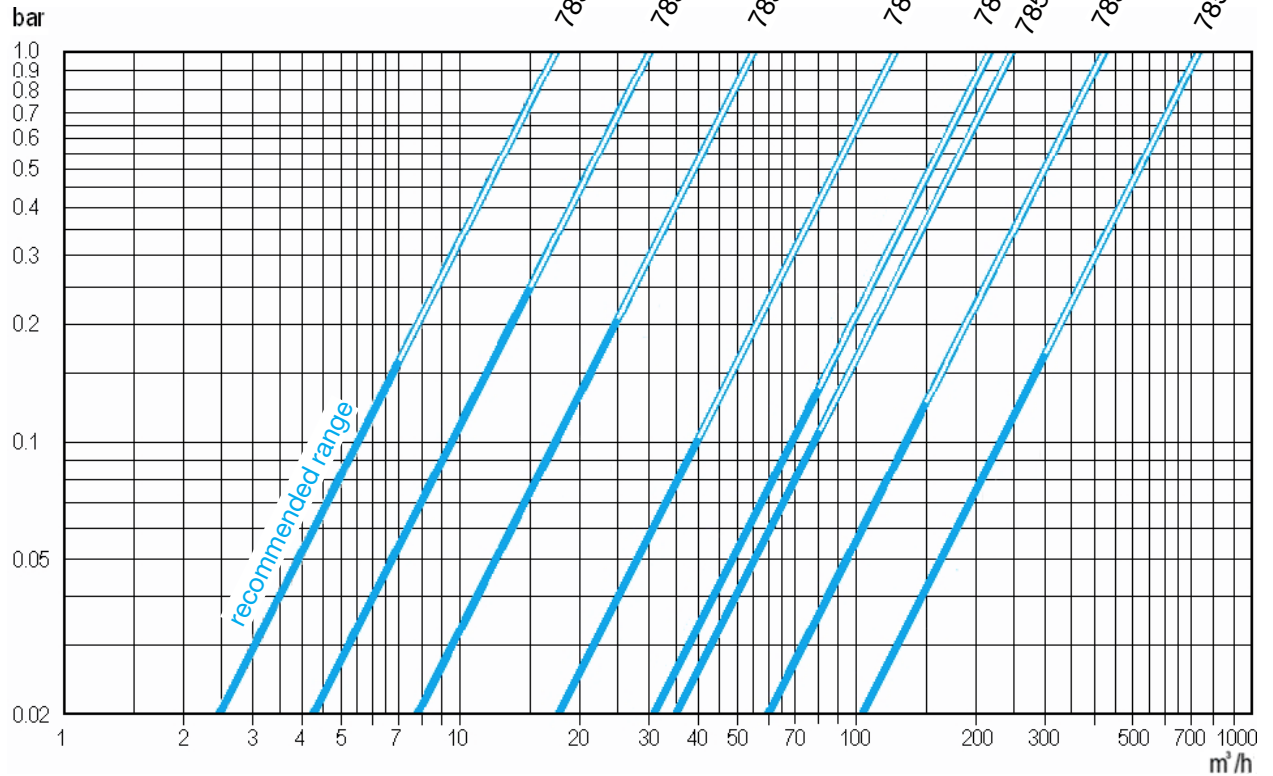

* For a clean filter and 130 micron screen

11.3 - Application guideline

For the selection of the correct automatic filter, it is imperative to take a number of variables into account. What is the origin of the water used, is it relatively clean – rainwater - or is it soiled – drain water? Next, the application of the filtered water is of importance: is it a pre-filtration for a disinfectant, or is it used for outside irrigation? The table below can be used as a guideline for the choice of the correct UdiMatic filter. These points are based on the average dirt load, which will determine the flushing frequency. Please consult your installer with respect to your specific situation.

All our recommendations are without obligation, and we cannot be held liable for any adverse consequences resulting from these recommendations.

maximum flow in m ³ /h						
	application	stock disinfectant	dripp irrigation capillary	dripp irrigation sprinkle < 1,3mm	sprinkle 1,3 - 1,8 mm	ext sprinkle > 1,8 mm flushing water
filter micron	water quality	75	100	130	200	300
1" (270 cm²)	good	3	4	5	6	7
	contaminated	1	2	3	4	5
1½" (850 cm²)	good	8	10	12	15	15
	contaminated	6	8	10	12	15
2" (850 cm²)	good	10	13	16	20	20
	contaminated	8	10	12	16	20
3" (1450 cm²)	good	25	30	35	38	40
	contaminated	15	20	25	30	35
4" (2360 cm²)	good	50	60	65	75	80
	contaminated	30	40	50	55	60
4" (4500 cm²)	good	80	80	80	80	80
	contaminated	80	80	80	80	80
6" (4500 cm²)	good	110	130	140	150	150
	contaminated	80	90	100	110	120
8" (6200 cm²)	good	180	230	250	300	300
	contaminated	100	130	140	160	200



Data Filtron flushing controller:

Customer:

Provided with: Udimatic / Galileo / Seperate

Delivery date:-.....-.....

Settings of this Filtron flushing controller:

Flush Time	Spoeltijd	Sec.
Flush Mode	Tijd/DP/Off
Main valve	Hoofdafsluiter	Yes / No
Dwell Time	Vertraging tussen stations	Sec.
DP Delay	Vertraging tot werkelijk spoelen	Sec.
Looping Limit	Endless-loop probleem	Yes / No
Alarm	Alarm	Yes / No
Delay Valve	Vertragingsklep	Yes / No
Pressure Units	Druk units	Bar / Psi
Calibration	IJking	Does not affect operation
Version display	Versie weergave	Does not affect operation
Number of plug-in modules	

Specifics:

.....

.....

.....

For change of settings, disconnect power. The Filtron will reset and activate the new setting.